

# Paperless Recorder



Type: PHU

PAPERLESS RECORDER PAPERLESS RECORDER PAPERLESS RECORDER



**Long Term Record Data Saving**  
3years in Compact Flash  
(In case of using 512MB Compact Flash)



**Saved Data playback**  
Saved data in Memory card can be easily called out and played back on display



**Math and totalization**  
These functions are available as standard.



**Communication**  
Ethernet (10Base-T) is available. (option)



**Screen saver**  
Period of non-operation exceeds the setting value of parameter, recorder turns off the backlight of LCD.



**PC support softwares (Data Viewer/Parameter Loader)**  
Supplied in a CD-ROM as a part of standard accessory



**36-point max. recording**  
12 types of thermocouples, 5 types of resistance bulbs and voltage/current input are available

PAPERLESS RECORDER

# Memory Card Data Saving

Provides flexibility and variety in the handling of record data.

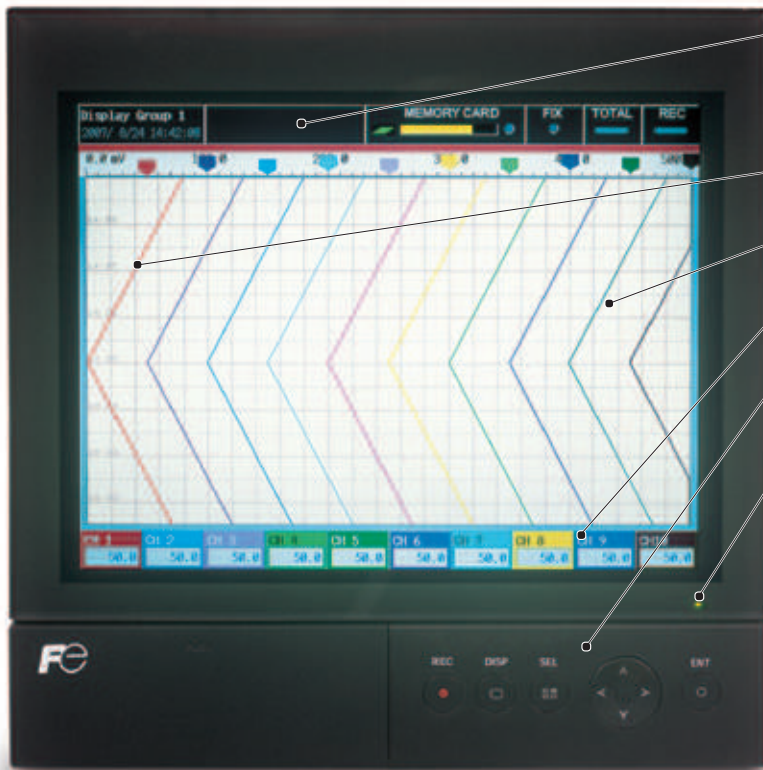

## Status Display

Allows you to display screen name, calendar, alarm information, recording status, writing status of measured data in Compact Flash, and fitting status of the card into the recorder slot.

## Time display

Indicates the time and time scale of recorded data.

## Trend Display

Allows you to view measured result in waveforms.

## Digital Display

Allows you to view measured values in a digital form.

## Key panel

Allows you to perform the recording start/stop, selection of display, setting, data display/change.

## Power indicator

During power on, LED turns on.  
While screen saver is working, it flickers.



About 3 years' worth of data can be recorded in Compact Flash (512 MB).

When recorded in ASCII mode, for 9 channels, and with a recording cycle of 30 seconds.

## Mathematics function (programming formula) as standard

### You can program formula using below operand.

Addition, Subtraction, Multiplication, Division Absolute value, X to the power of Y, Logarithm, Natural logarithm, Exponential function, Humidity, Average value, Maximum value, Minimum value.

## Communication

Ethernet (10Base-T) is available. It has FTP, HTTP (Web server), SMTP and MODBUS-TCP protocols.

## Calculation function offered as standard

### Subtraction

Difference between the values of each channel can be calculated.

### F value calculation

Extinction rate of bacteria by heat sterilization can be calculated per channel according to the measured temperature.

### Totalization

Measured value of each channel can be totalized.

Reference time can be selected from day, hour, minute and second.

### Square root extraction

Square root extraction of the input value of each channel can be performed.



# Wide variety of display mode

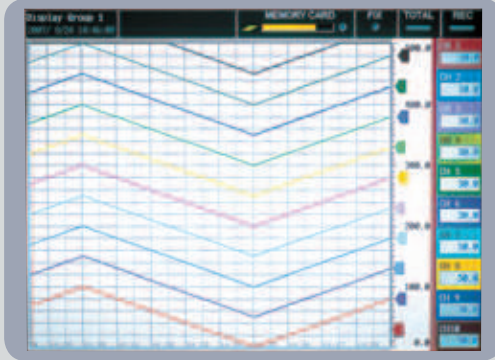

## Trend recording (horizontal)

Measured result is horizontally displayed in real time.

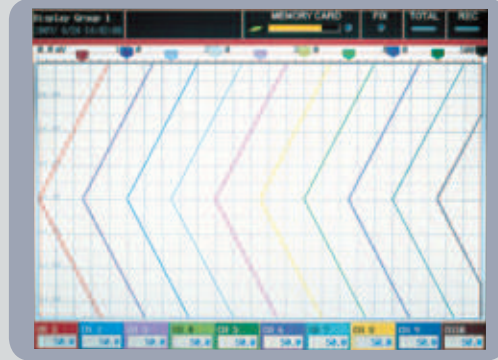

## Trend recording (vertical)

Measured result is vertically displayed in real time.



## Bar graph

Measured values are displayed in bar graph.



## Analog meter

Measured values are displayed in analog meters.



## Digital display

Channel No., Tag No. engineering unit, and alarm information are displayed in digital form, in addition to measured values.



## Totalized data display

Totalized data of each channel is digitally displayed. (If power failure occurs while in totalizing operation and the power is restored later, the data being totalized is cleared.)

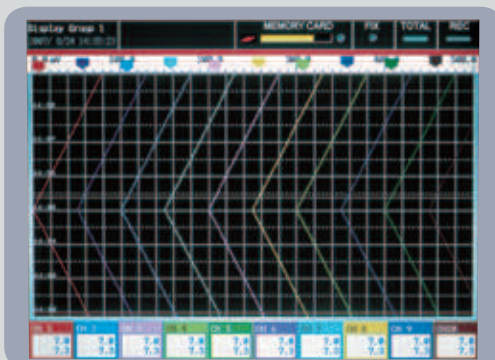

## Historical trend display

Past data saved to Compact Flash can be viewed. Scroll function is usable.

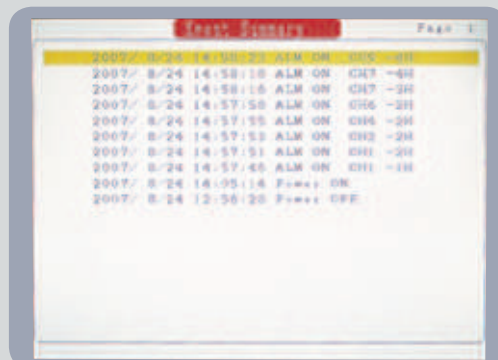

## Event summary display

Alarm status and external control input status for each channel are displayed.

# Specifications

## General specifications

Mounting method	Panel flush mounted
Material	steel sheet for case, PC-ABS for bezel
External dimensions and mass	<Panel mount> 300 x 300 x 220.5 mm, about 4.7 kg (9-point input)
Power supply voltage	100V to 240V AC, 50/60 Hz
Power consumption	About 80VA (at 240VAC)
External terminals	Screw terminals (M3 thread)
Operate temperature	0 to 50°C (in case the 12th digits of code symbols is "Y".) 0 to 40°C (in case the 12th digits of code symbol is "E" .)

## Input unit

No. of inputs	9 or 18 or 27 or 36 points
Measuring cycles	100ms/9, 18 points 200ms/27, 36 points
Recording cycle	1sec to 12hours
Input signal	Thermocouple: 12 types (B, R, S, K, E, J, T, N, W, L, U, PN) Resistance bulb: 5 types (Pt100, JPt100, Ni100, Pt50, Cu50) DC voltage: (0 to 50mV, 0 to 500mV, 0 to 5V or 1 to 5V) DC current: (connecting optional shunt resistor to input terminal)
Input types	Selected from the key panel (the same type should be set for every 2 channels)
Burn-out function	Equipped with thermocouple and resistance bulb inputs as standard.
Calculation function	Primary delay filter, scaling, calculation of difference between channels, F value calculation, totalization, and square root extraction

## Mathematics function

Formula	It can be set 1 main formula and 3 temporary one. Addition, Subtraction, Multiplication, Division Absolute value, X to the power of Y, Logarithm, Natural logarithm, Exponential function, Humidity, Average value, Maximum value, Minimum value.
Input signal	DI (DI1 to DI16), Totalize (ch1 to ch72), Analog input (ch1 to ch72), Constant (No.1 to No.60), Communication input (No.1 to No.36)

## Display unit

Display	12" TFT color LCD (800 X 600 dots) (The LCD may have some pixels that do not stay on or off. Due to the characteristics of liquid crystal, the brightness may not be uniform, which is not a failure.)
Life of backlight	50,000 hours
Display contents	<ul style="list-style-type: none"> <li>•Trend display (in vertical and horizontal direction) selected in the refreshment cycles of 1 sec to 12 hours. Scale display/non-display selectable</li> <li>•Bar graph or analog meter display (refresh cycle: 1 second)</li> <li>•Digital display (in refreshment cycle of 1 sec)</li> <li>•Event summary display (alarm and message summary)</li> <li>•Historical trend display (Compact Flash memory data.)</li> <li>•Totalized data display</li> <li>•Group setting (8 groups at the maximum)</li> </ul>

## Recording function

Recording medium	Compact Flash card (Format as FAT16 or FAT, or recorder can't read and write.)
------------------	--

Memory capacity	1GB, max.
Recording method	Writing starts in fixed cycles by turning ON the REC key on the front panel. Data is recorded in a new file every time the recording starts.
Data save cycles	Links to refreshment cycle of the trend display
Data format	<ul style="list-style-type: none"> <li>•ASCII About 166 bytes per sampling (at 9 channel inputs)</li> <li>•Binary (Data cannot be read directly into Excel, etc.)</li> </ul> About 40 bytes per 1 sampling (9-channel input)
Trend data	Maximum value and minimum value are saved from the data that are sampled in measuring cycles.
Event data	Alarm data and message data are saved.
Totalized data	Stores data totalized during specified period of time.
Storage capacity	<ul style="list-style-type: none"> <li>•About 1.5 years at display refresh cycle of 30 seconds (ASCII)</li> <li>•About 6 years (Binary)</li> </ul> (9-channel recording, 256MB compact flash used)
Amount of memory used	The display unit displays how much the memory card has been used via bar graphs. The recording will stop if the amount of recorded data exceeds the capacity.

## Alarm function

No. of settings	Up to 4 alarms are settable for each channel.
Type of alarm	High/Low limits
Indication	Alarm status is displayed on digital display unit when an alarm occurs. Histories are displayed in the alarm summary.
Output	20 points as relay output (option) 16 points as open-collector transistor output (option)

## Reference performance

Indication accuracy	±(0.15%+1 digit) of input range Accuracy of the next range is ±(0.3%+1 digit). Thermocouple B: 400°C to 600C, thermocouples R and S: 0°C to 300°C, thermocouples K, E, J, T, L, and U: -200°C to -100°C
Indication resolution	0.1°C
Reference junction	±0.5°C
Compensation accuracy	(Thermocouples R, S, B and W: ±1.0°C)
Input resistance	About 1MΩ

## Others

Clock	With calendar function
Memory backup	Parameter settings are saved to the internal non-volatile memory. The clock is backed up by a built-in lithium battery. Trend data is back up 5 Mbyte.
Memory full alarm	When the amount of recorded data exceeds the capacity of memory card, recorder can energize the alarm output.
Low battery alarm	When the battery for backup of clock and SRAM becomes low, recorder can energize the alarm output.

## Optional specifications

Alarm relay output	Up to 2 pieces of card, having 10-point relay output, can be mounted (max.20points). Alarm output: 1 a contact Alarm setting: individual channel or common output is available.
--------------------	---

# Specifications

Alarm open-collector output	A card, having 16-point open collector output, can be mounted. Alarm output: open collector output	<b>PC support software (standard-supplied CD-ROM)</b>	
DI input	A card, having 16-point DI input, can be mounted. DI input: no-voltage contact input Contents of control: Recording start/stop, Message setting, F value calculation resetting, Totalizing start/ stop, Totalizing reset, LCD turning.	O/S PC/AT-compatible machine	Windows XP/2000 Operation on PC98-series machines by NEC is not guaranteed. Operation on self-made or shop-brand PCs is not guaranteed.
Communication (Ethernet)	10Base-T FTP server * (Internet Explorer 6. FFFTP or Comand Prompt are available) HTTP server * (Web server. Internet Explorer 6 is available) SMTP (e-mail client) MODBUS-TCP * Netscape and Mozilla Firefox are not available	Required memory capacity	64 MB or more
		Contents	The following types are included as standard. 1) Data viewer software It allows you to view the past trend recorded data from the data saved to the Compact Flash on PC. Historical trend and event display functions are provided. 2) Parameter loader software It allows you to perform setting/change of various parameters on PC.

## A convenient PC support software package is included as standard

Past data saved to Compact Flash can be viewed on personal computer.

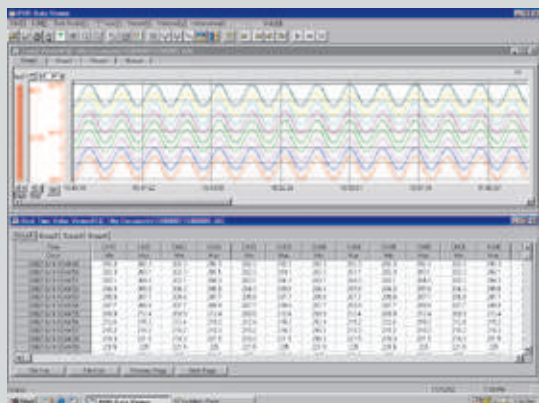

Historical trend data screen

Parameters for the recorder can be easily set and changed from personal computer.

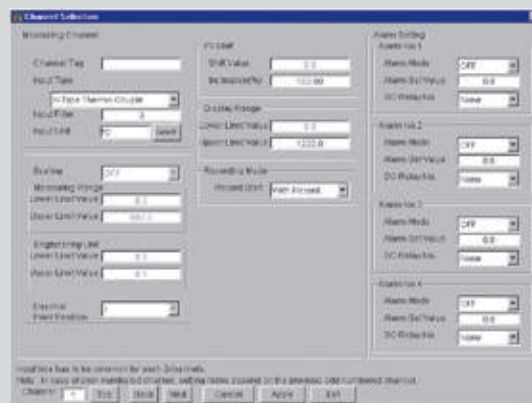

Parameter setting screen



Before use, install PC support software supplied as standard.

- O/S: Windows XP/2000
- Required storage capacity: 64 MB
- Provide PC card adapter separately.

Recommended type: SDAD-38 (SanDisk Co.)

PC/AT-compatible machine

- Operation on PC98-series machines by NEC is not guaranteed.
- Operation on self-made or shop-brand PCs is not guaranteed.



Before use, install PC support software supplied as standard.

- O/S: Windows XP/2000
- Required capacity of memory: 64 MB
- A communication cable between recorder and pc is optional.

Type: PHZP1801

PC/AT-compatible machine

- Operation on PC98-series machines by NEC is not guaranteed.
- Operation on self-made or shop-brand PCs is not guaranteed.



# Outline Diagrams (Unit: mm)

## 9 input points

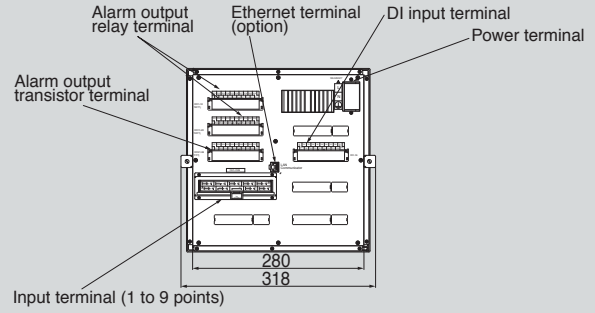
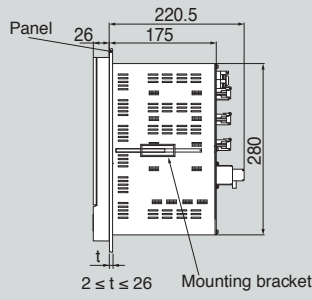
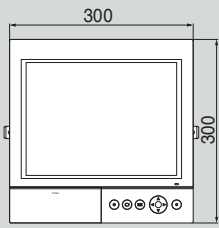

## 18 input points

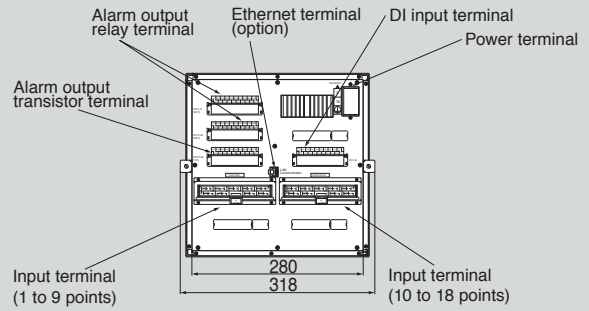
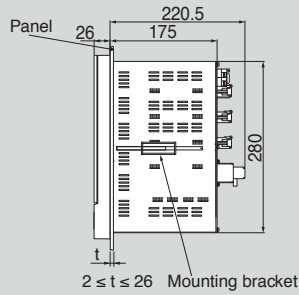
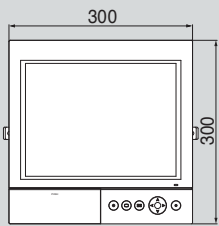

## 27 input points

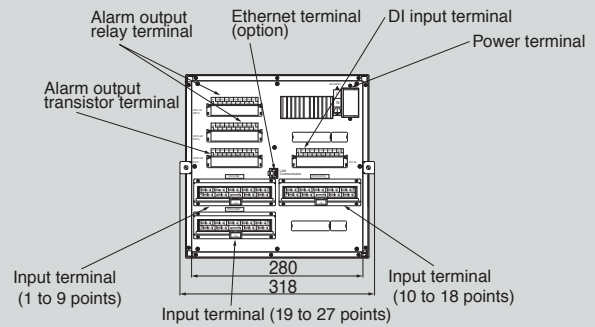
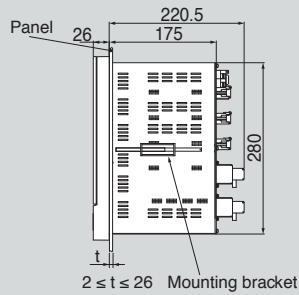
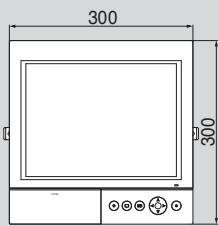

## 36 input points

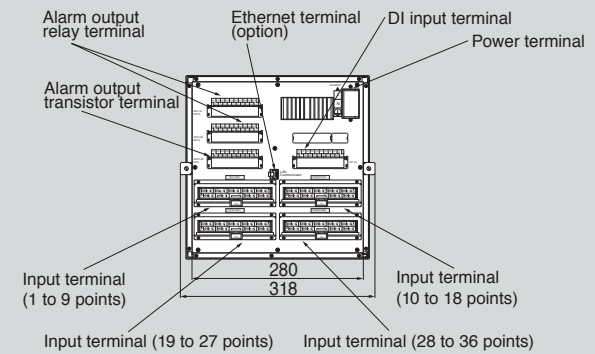
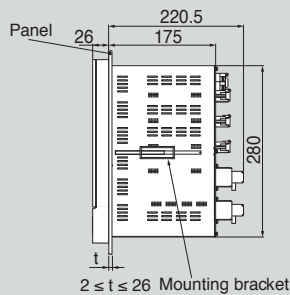
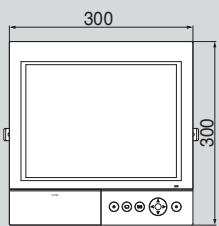

### Panel cutout

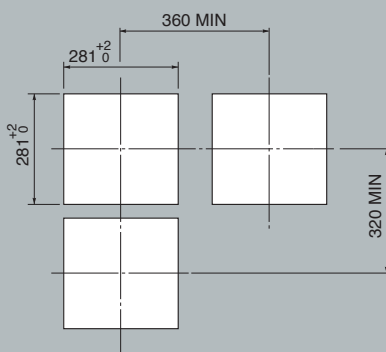

# External connection diagrams

## Alarm output relay terminal

M3 screw

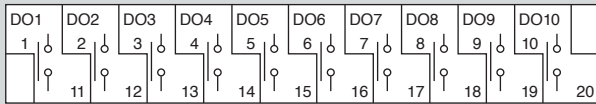

## Alarm output relay terminal

M3 screw

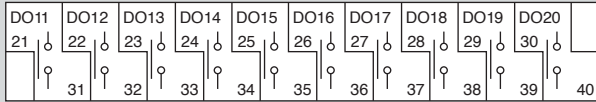

## Alarm output transistor terminal

M3 screw

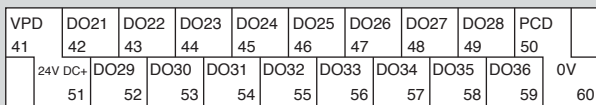

## Power terminal

M4 screw

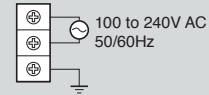

## DI input terminal

M3 screw

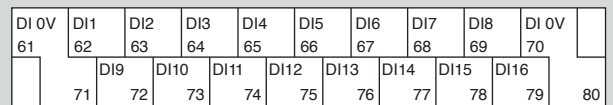

## Input terminal

M3 screw

Number of input points = 1 to 9 points

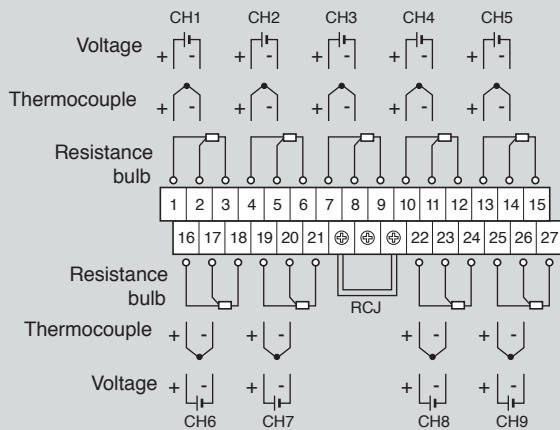

Number of input points = 10 to 18 points

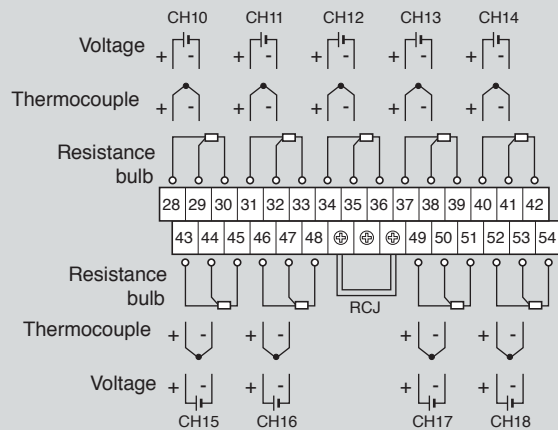

Number of input points = 19 to 27 points

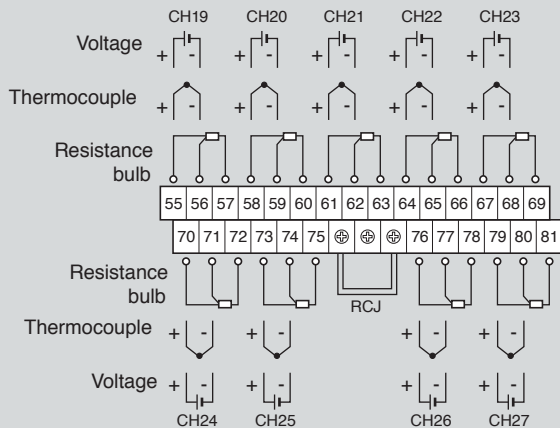

Number of input points = 28 to 36 points

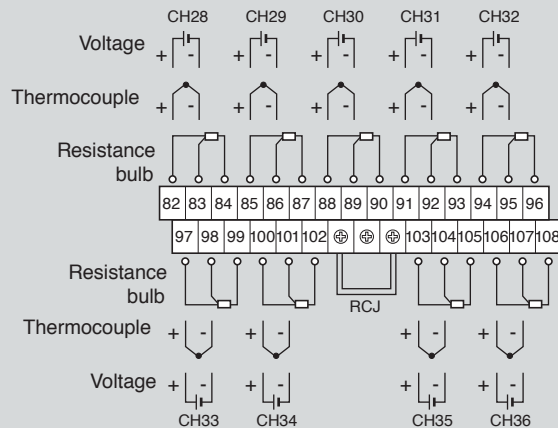

Note) For current input, connect an optional shunt resistance to a voltage input terminal.

# Code Symbols

Digit	Specifications	Note	4	5	6	7	8	9	10	11	12	13
4	<Number of input points> 9 points 18 points 27 points 36 points		↓									
7	<DI input> Without With (16 points)					↓						
8	<Modification No.(fixed)>						↓					
9	<Display (instruction manual)> English							↓				
11	<Alarm output> Without 10 relay points 20 relay points Transistor (open collector) 16 points 10 relay points + transistor (open collector) 16 points 20 relay points + transistor (open collector) 16 points								↓			
12	<Ethernet> Without With									↓		

Note: Input signals are classified into the following 4 groups. Make the setting so that the consecutive 2 channels (1ch and 2ch for example) are assigned the input signal categorized in the same group.

Group 1: Thermocouple (12 kinds), 50mV

Group 2: Pt100, JPt100, Ni100, Cu50, Pt50

Group 3: 500mV

Group 4: 1-5V, 0-5V

Input signals can be arbitrarily selected for channels 9 and 18 and 27 and 36.

# Scope of supply

Item	Quantity
Main unit	1
Panel mounting bracket	1
CD-ROM (PC software and Instruction manual)	1
Noise filter for power cable	1

## Option

Item	Type	Specifications
Shunt resistor for DC current input	PHZP0101	10Ω±0.1%
PC loader communication cable	PHZP1801	With USB A and USB miniB Connector
CD-ROM (PC software and instruction manual)	PHZP2501	
PC card adapter for Compact flash	PHZP0501	Maker : Sandisk
Compact flash (512MB)	PHZP1301-512	

Note 1: Windows, Excel and Internet Explorer are registered trademarks of Microsoft Corporation.

Note 2: SanDisk compact flash is a trademark of SanDisk.

Note 3: PC98 series are registered trademarks of NEC Corp.

Note 4: MODBUS® is the registered trademark of AEG Schneider Autmation International.

Note 5: Netscape is the registered trademark of Netscape Communication Corp.

Note 6: Mozilla Firefox is the registered trademark of Mozilla Foundation.

# Fuji Electric Co., Ltd.

International Sales Div.

Sales Group

Gate City Ohsaki, East Tower, 11-2, Osaki 1-chome,  
Shinagawa-ku, Tokyo 141-0032, Japan

<http://www.fujielectric.com>

Phone: 81-3-5435-7280, 7281 Fax: 81-3-5435-7425

<http://www.fujielectric.com/products/instruments/>